



LEADER IN INNOVATION OF VEGETABLE DRINKS

# Factory in Monte di Malo





We are a company with **60** employees  
Founded in **2018** by a group of families





## VISION

To exclusively produce for the private label  
the best vegetable-based products  
at the most competitive price



## MISSION

Almas, seeking customer satisfaction, reducing costs  
and combining innovation with respect for the environment,  
develops tailor-made vegetable-based products  
by performing  
all production processes

I The foundations of the Company Policy are:

FOOD SAFETY

QUALITY'

SUSTAINABILITY

ENVIRONMENT

ETHICS



# VALUE PROPOSAL

WE OFFER TO OUR CUSTOMERS:

The vegetable products market is constantly looking for products that respond to the demand for genuine, safe and innovative foods, working with natural and increasingly controlled ingredients

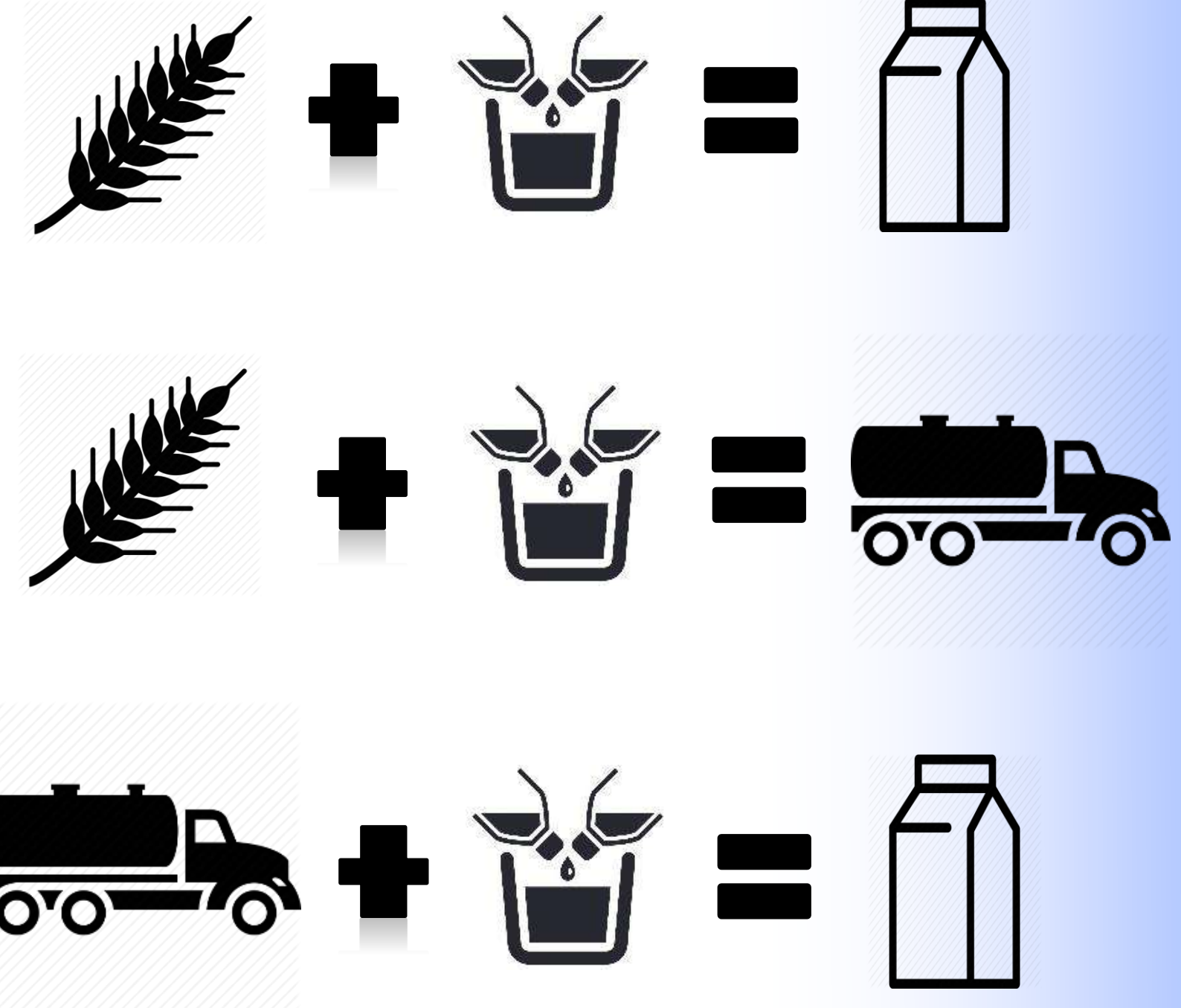

# Tre modalità di produzione e fornitura ALMAS per soddisfare al meglio le vostre esigenze.

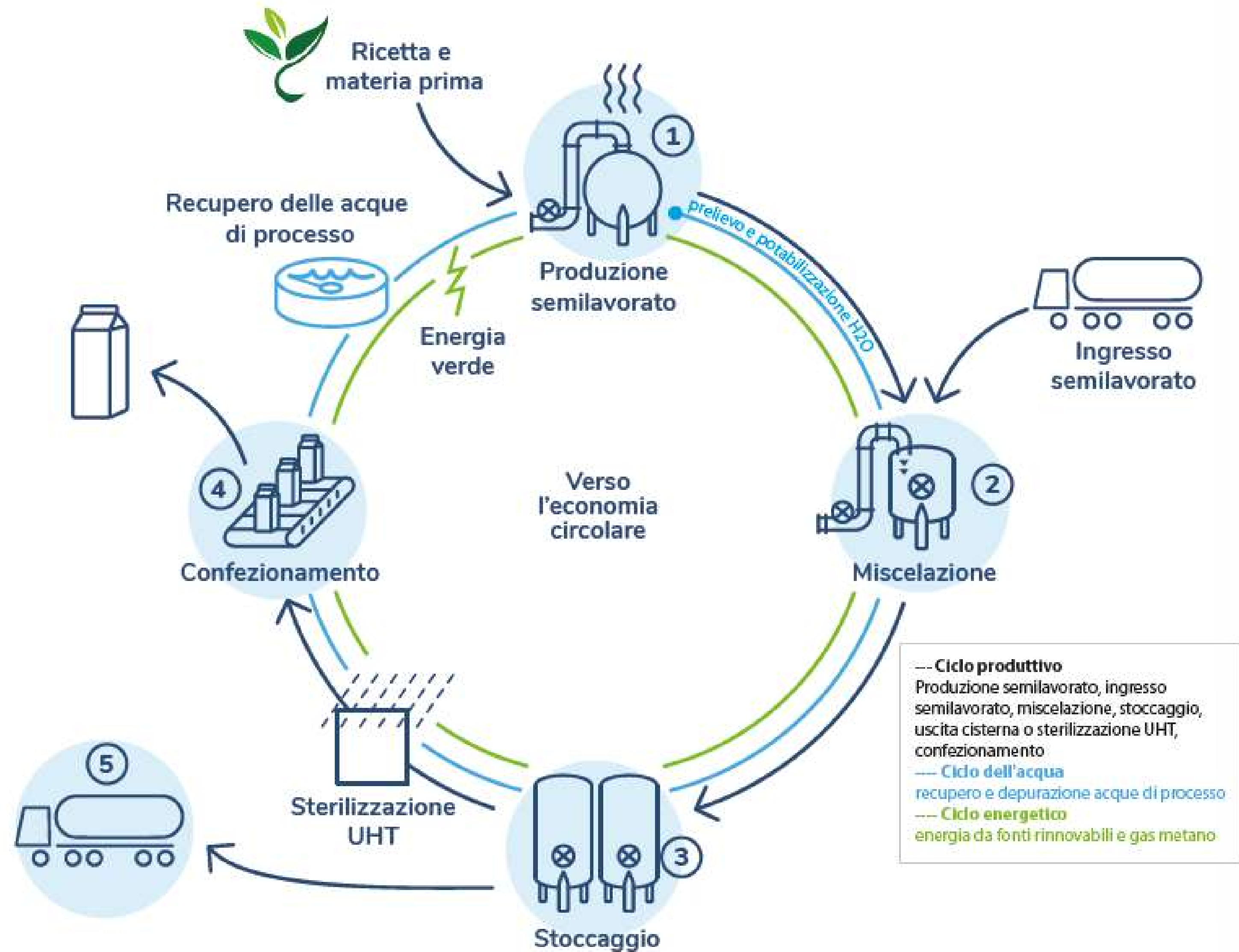

--- **Ciclo produttivo**  
Produzione semilavorato, ingresso semilavorato, miscelazione, stoccaggio, uscita cisterna o sterilizzazione UHT, confezionamento  
--- **Ciclo dell'acqua**  
recupero e depurazione acque di processo  
--- **Ciclo energetico**  
energia da fonti rinnovabili e gas metano

1 → 4  
Il Tailor-made

1 → 5  
Il semilavorato

2 → 4  
La sinergia di produzione  
dalla cisterna al brick.



# OUR MARKETS



We don't have our brand, but we exclusively produce  
For **PRIVATE LABEL**

Our customers are RETAILERS, DISTRIBUTORS,  
SPECIALIZED SHOPS, INDUSTRY located for:

45 % in ITALY

55 % in EUROPEAN and EXTRA-EU countries

Every year, for the Italian  
market we attend the show:



For the International  
market the show :

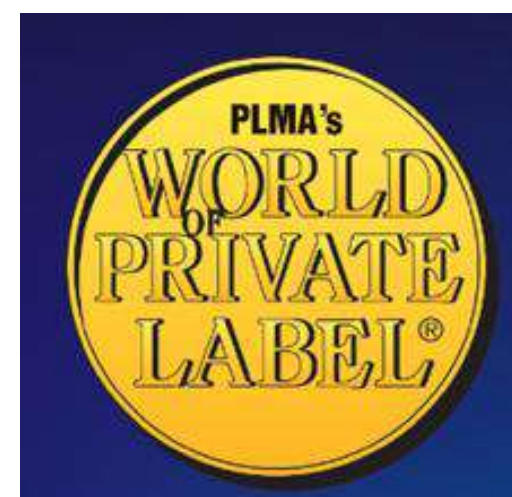



# AWARDS



Our business has received for **two years in a row** the recognition of Best Copacker Profile **1st** place in the beverage sector





# AWARDS

This year, our  
Hazelnut and Oat  
drink was awarded  
**BEST FOOD  
PRODUCT** by a jury  
of retail buyers and  
industry managers





Eliana Carretta  
Head of Quality Assurance



## CERTIFICATIONS

The maximum commitment for the **QUALITY**

Almas produces in compliance with **quality management systems** compliant with the international process and product certification standards indicated here:





## FOOD DEFENCE

Almas has implemented a series of safety programs to protect production, personnel and company know-how from risks of alteration due to voluntary or involuntary external or internal acts





## ETHICS

Almas involves all internal and external stakeholders in its ethical choices, striving to ensure the **well-being, continuity and safety** of the working environment.



# SUSTAINABILITY

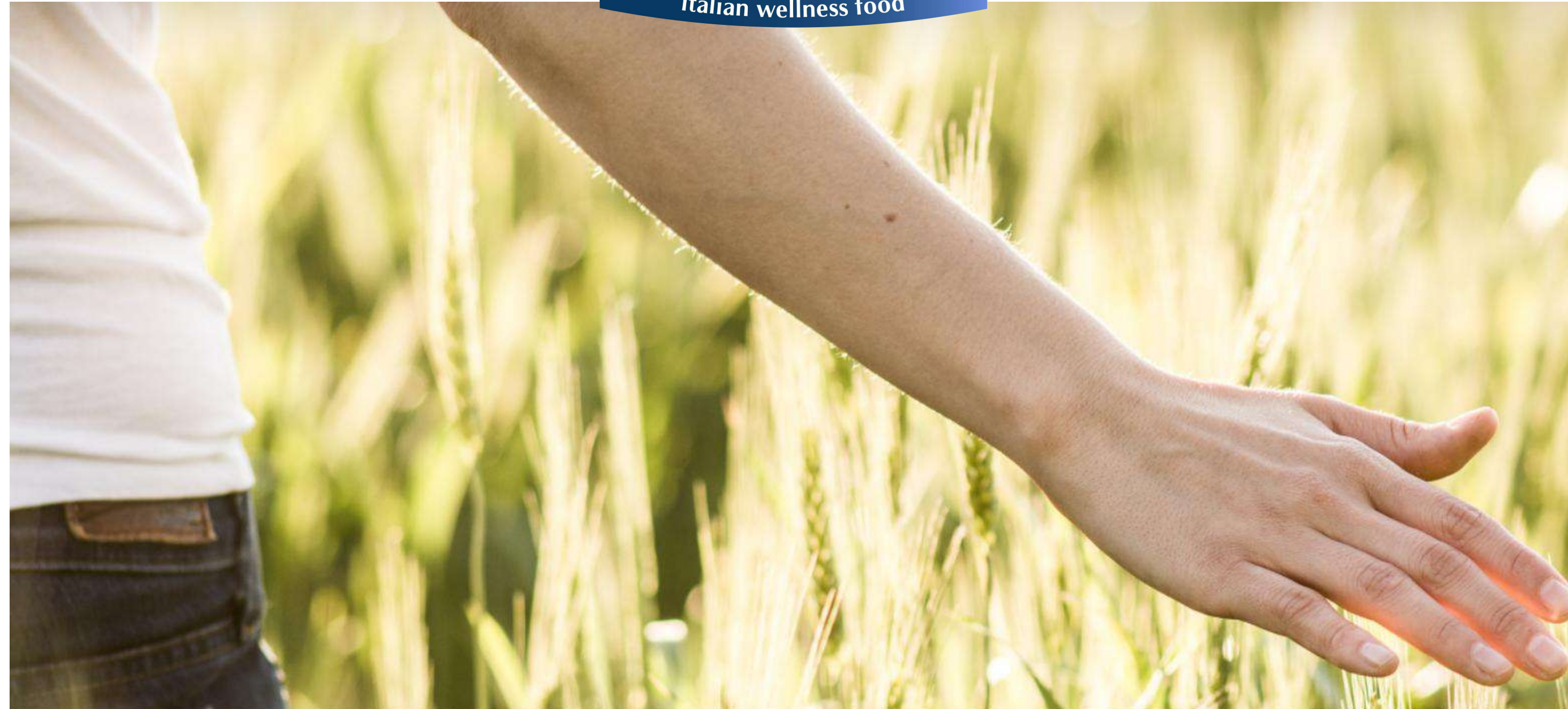

## Only with balance we can build the future

Almas's sustainability values to ensure **balanced growth**, in compliance with the internal and external value chain are:

- being proactive in a community that is attentive to **people's needs**
- providing healthy plant-based products, favoring **short supply chains**
- **reducing climate change** with our choices, with our activities and by networking
- **anticipating positive changes** with research and the application of innovation



## STRONG EXPERTISE IN THE PURCHASES

We use certified supply chain plant ingredients carefully selected for high quality and traceability. It is important for us to **ensure a long-term partnership** with growers, in order to maintain high standards of food safety and quality.



## Value Proposition - Assortment



Non-dairy milks | vegetable creams| Vegetable soups and broths | Vegetable desserts



Cereals and seeds



Legums



Nuts

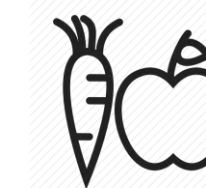

Fruit and vegetables

**Con Glutine**

**Senza Glutine**

Oat

Rice

Soya

Barley

Quinoa

Lentils

Spelt

Millet

Chickpeas

Kamut

Sorgo

Peas

wheat

Buckwheat

Other vegetables

Certified gluten free  
oats

**Fruit**

**Vegetable**

Almond

Ananas

Potato

Coconut

Lemon

courgettes

Hazelnut

Apricot

Red turnip

Pistachio

Peach

Carot

Cashew

Pear

Onion

Macadamia

Orange

Other vegetables

Other fruit



Value proposition- R&D

KNOW-HOW



Product Innovation = Giving the opportunity to combine ingredients for the creation of new products with the possibility of working with specific raw materials requested by the customer

Technological Innovation = Constant research for innovation that leads to the continuous improvement of extraction techniques and production technologies

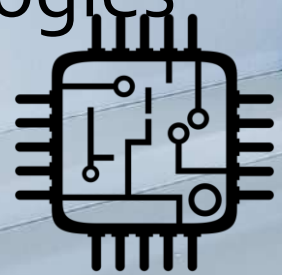

CONTINUOUS INNOVATION  
IN RESEARCH





## 4.0 INDUSTRY

All the stages of the production process, from the extraction of the beverage, to the packaging, up to the storage and shipping, are managed using 4.0 technology.





## Key Resources



Know How developed thanks to many years of consolidated experience in the reference market

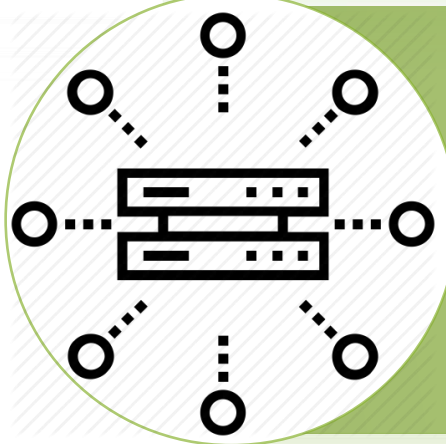

Integrated Management of the Entire Production Process



Continuous search for innovation in the Production Process





We have two packaging lines  
**Tetra Edge**  
for 1L and 500 ml





Tetrapak Brik 0,5 L Edge. &



Tetrapak Brik 1 L Edge

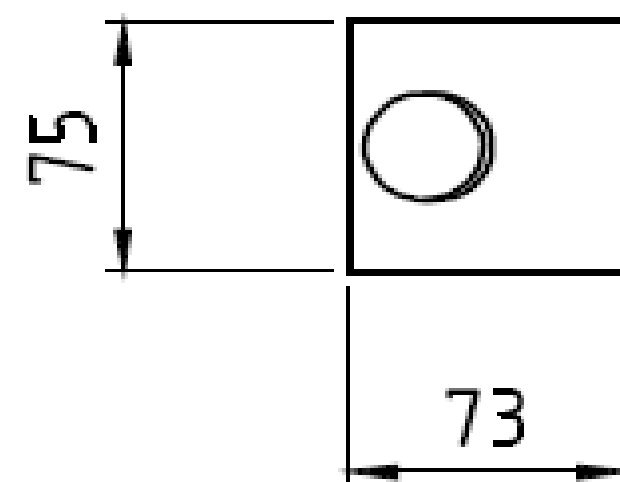
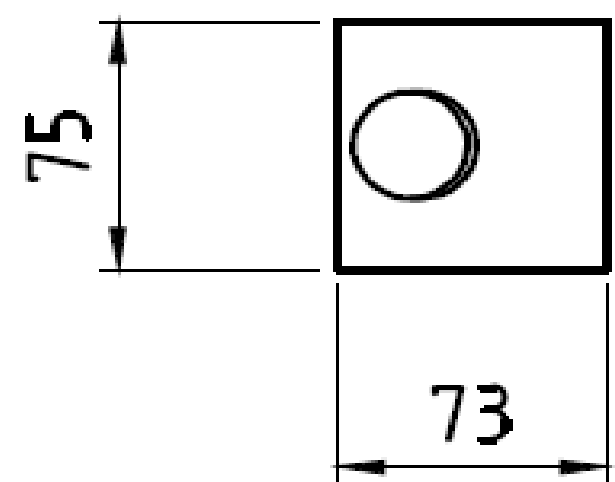
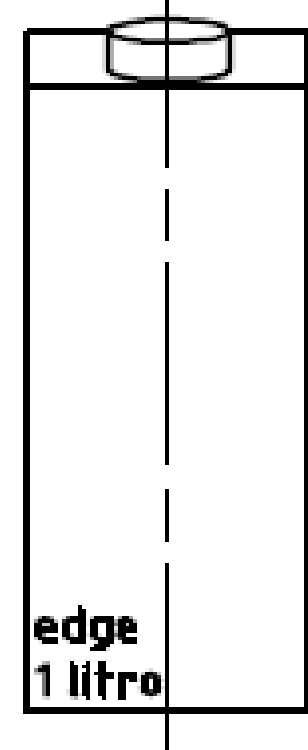
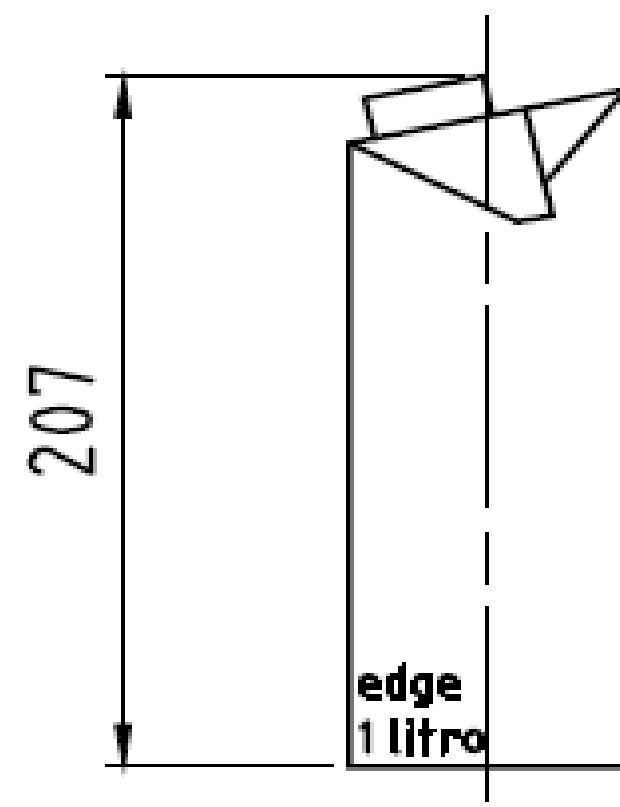
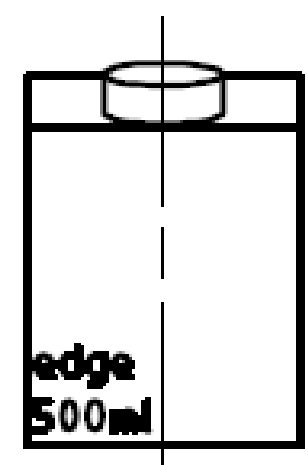
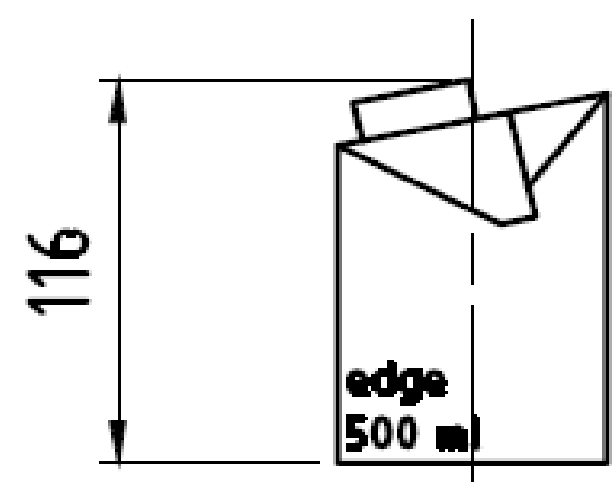

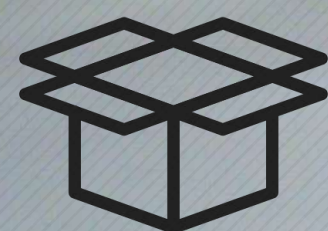

Flexible secondary packaging  
with multiple possibilities for combining box formats



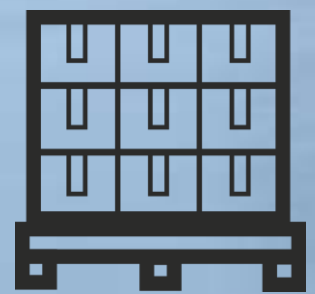

**Flexible tertiary packaging**  
with multiple composition possibilities and pallet formats  
Each pallet is identified with a unique SSCC code

## Schema logistico di confezionamento

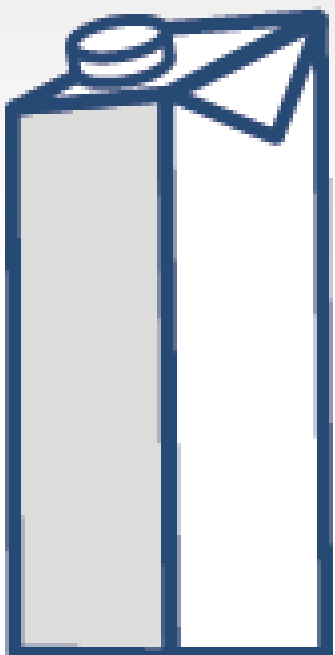
FORMATO	PEZZI PER CARTONE	PALLET	STRATI PER PALLET	CARTONI PER STRATO	CARTONI PER PALLET	PEZZI PER PALLET	PESO LORDO PALLET kg
<b>500 ML</b> 	6 (2X3)	80x60 (1/2 PALLET)	10	12	120	720	420
		80x120	10	25	250	1.500	850
		100x120	10	31	310	1.860	1.050
	12 (3X4)	80x60 (1/2 PALLET)	10	6	60	720	420
		80x120	10	13	130	1.560	890
		100x120	10	17	170	2.040	1.150
<b>1000 ML</b> 	6 (2X3)	80x60 (1/2 PALLET)	5	12	60	360	420
		80x120	5	25	125	750	850
		100x120	5	31	155	930	1050
	8 (2x4)	80x60 (1/2 PALLET)	5	9	45	360	420
		80x120	5	19	95	760	860
		100x120	5	23	115	920	1.040
	10 (2X5)	80x60 (1/2 PALLET)	5	7	35	350	410
		80x120	5	15	75	750	850
		100x120	5	19	95	950	1.070
	12 (3X4)	80x60 (1/2 PALLET)	5	6	30	360	420
		80x120	5	13	65	780	880
		100x120	5	17	85	1.020	1.150

MADE TO ORDER

Productions made to customer order

MADE TO STOCK

Plannable productions in stock

VOLUME  
2025

50.000.000  
OF LITERS  
PRODUCED



PRODUCTION  
CAPACITY

LITERS  
60.000.000

Investments in the second PRODUCTION LINE and the expansion of the LOGISTICS WAREHOUSE have allowed us to **double our production capacity**



Evelina Libralesso  
Head of Administration and  
Finance



Almas is also witnessing growth  
according to  
Best Performer 2024  
**Company**





# SKILLS





# Skills



**Andrea Tomelleri** Over forty years in the food sector, most of which as CEO, he has a great knowledge of the reference market

**Patrizia Zerbato** Sales Manager with many years of experience in the vegetable drinks sector and expert in the international market



# SOLIDARITY



ALMAS DONATES PART OF THE PROCEEDS TO SUPPORT TWO PROJECTS OF STRONG SOCIAL VALUE:

## Città della speranza (city of hope)

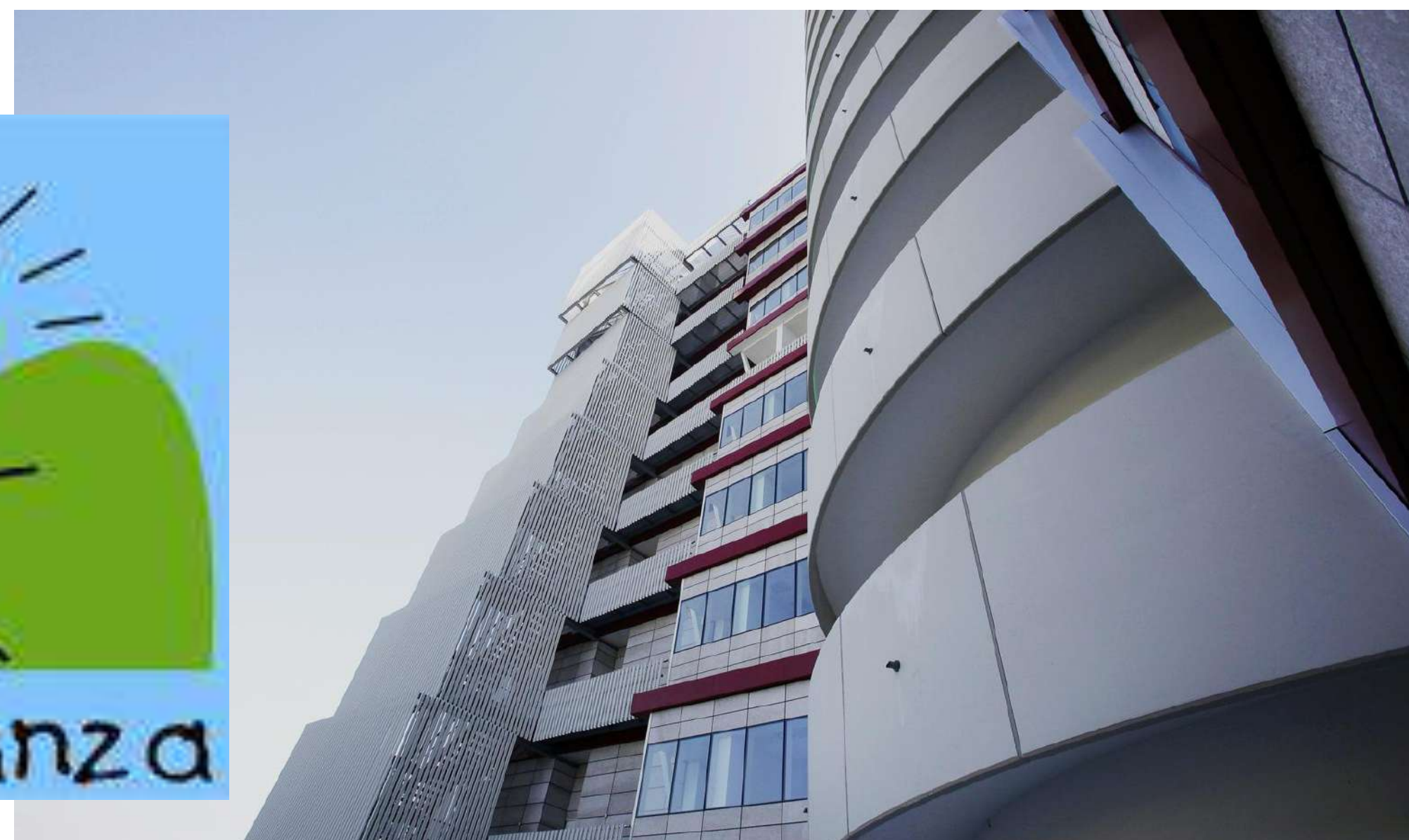

Since 1994, Fondazione Città della Speranza has aimed to improve the conditions of care and assistance for children with oncohematological diseases, as well as to finance scientific research in the pediatric field. Thanks to the help of companies, associations, private citizens and the strength of volunteering, it has created and supports:

- the Pediatric Oncohematology Clinic of Padua, a national reference center for the diagnosis of leukemia, lymphomas and sarcomas.
- the Pediatric Research Institute Città della Speranza, the largest European research center in this field that has contributed significantly to increasing recovery rates, taking them from around 30% in 1994 to 85% today. The treatment protocols, developed in its laboratories, are adopted in 51 countries around the world.

More information on the website [www.cittadellasperanza.org](http://www.cittadellasperanza.org)



# SOLIDARITY



## Matteo Sacchi Foundation



“A Project of reception, schooling and education in the Matt House in Cuddalore-Tamil Nadu-India to prepare orphaned, disadvantaged or abused girls to believe in a dream, that of a better future”.

More information on the website: [www.matt.it](http://www.matt.it)

**THE FUTURE**  **almas**  
*italian wellness food*

**The next 2 years...**

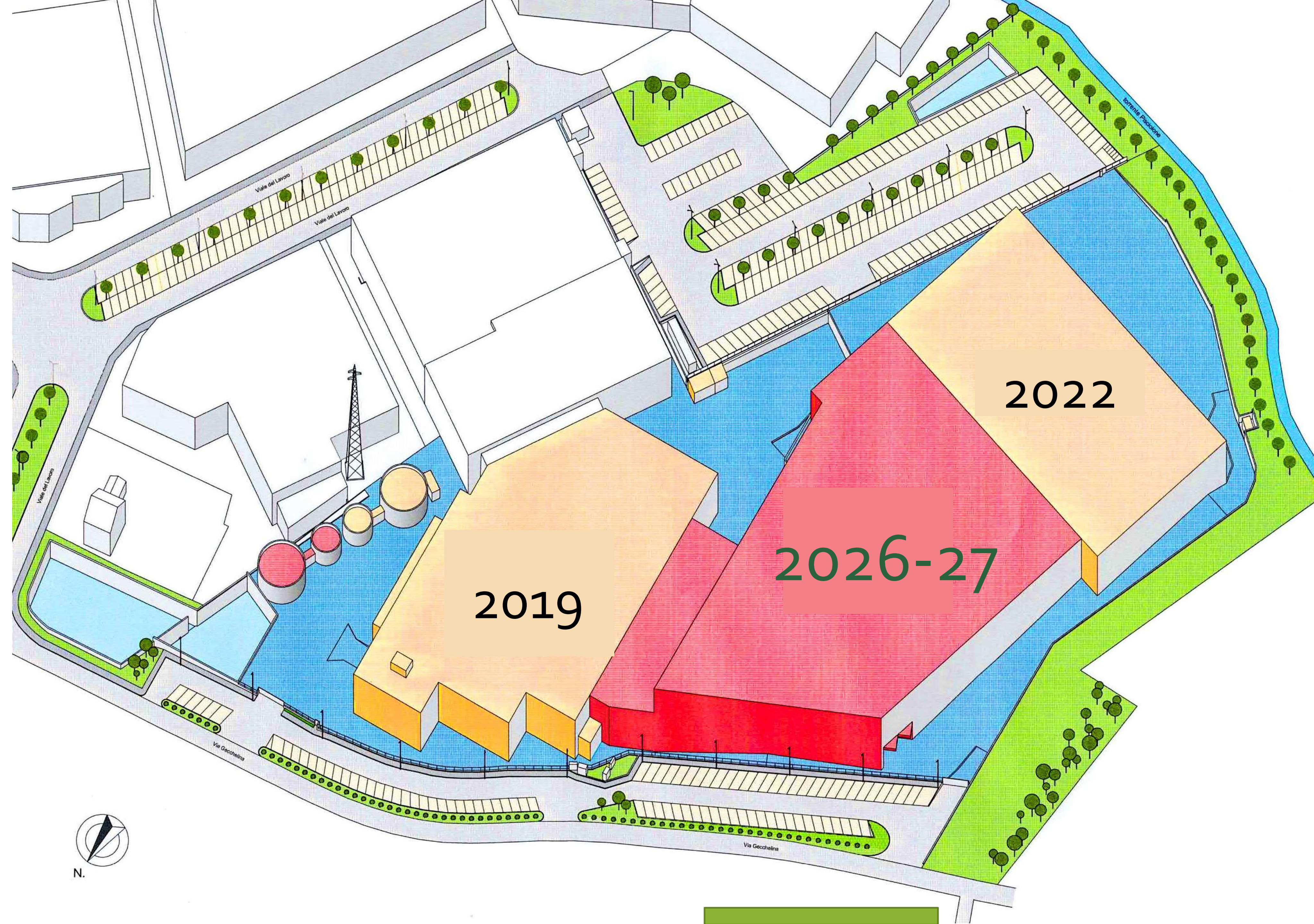

2019 Construction of production plant

2022 Costruction of warehouse for finished products

2026-2027 Construction of connection plant, expansion project

THANK YOU



[www.almasitalia.it](http://www.almasitalia.it)